

UNAKRSNO LAMELIRANI DRVENI ELEMENTI U SAVREMENIM DRVENIM KONSTRUKCIJAMA ZGRADA – primena i proračun

CROSS LAMINATED TIMBER ELEMENTS IN CONTEMPORARY TIMBER STRUCTURES OF BUILDINGS – application and design

Ljiljana KOZARIĆ
Aleksandar PROKIĆ
Miroslav BEŠEVIĆ

STRUČNI RAD
PROFESSIONAL PAPER
UDK: 624.011.1
doi: 10.5937/grmk1504051K

1 UVOD

Drvo je jedan od najstarijih građevinskih materijala i pored kamena je dugi niz godina bio osnovni materijal za građenje. Njegove karakteristike omogućavaju visok stepen prefabrikacije, brzu montažu na terenu i trenutnu useljivost. Zbog velike požarne otpornosti u požaru ne gubi nosiva svojstva, odnosno mehaničke karakteristike ne menjaju se bitno prilikom visokih temperatura. Drvene konstrukcije su pet puta lakše od armiranobetonskih, pa mogu lakše preuzeti seizmičke sile i predstavljaju dobar izbor u trusnim područjima. Objekti izgrađeni od drveta imaju visoku energetska efikasnost.

Poslednjih decenija, drvo se sve više primenjuje u izgradnji modernih arhitektonskih građevina (npr. sportskih objekata, stambenih zgrada, mostova) zahvaljujući boljem poznavanju drveta kao materijala, primeni savremenih drvenih konstrukcija i upotrebi kvalitetnih spojnih sredstava. Konstruktivni elementi savremenih drvenih konstrukcija bazirani su prvenstveno na savremenim proizvodima od drveta kao što su lepljeno lamelirano i unakrsno lamelirano drvo.

Ljiljana Kozarić, dipl. inž. građ., Univerzitet u Novom Sadu, Građevinski fakultet Subotica, Kozaračka 2a, Subotica, Srbija, tel.: 024 554 300, e-mail: kozaric@gf.uns.ac.rs
Prof.dr Aleksandar Prokić, dipl. inž. građ., Univerzitet u Novom Sadu, Građevinski fakultet Subotica, Kozaračka 2a, Subotica, Srbija, tel.: 024 554 300
e-mail: aprokic@eunet.rs
Prof.dr Miroslav Bešević, dipl. inž. građ., Univerzitet u Novom Sadu, Građevinski fakultet Subotica, Kozaračka 2a, Subotica, Srbija, tel.: 024 554 300
e-mail miroslav.besevic@gmail.com

1 INTRODUCTION

Wood is one of the oldest building materials and along with stone it is the basic building material. Its characteristics allow for a high degree of prefabrication, quick assembly, and immediate utilization. Wood has great fire resistance, and during the fire retains its characteristics, i.e. its mechanical properties do not change significantly due to high temperatures. Timber constructions are five times lighter than reinforced concrete, thus they are better capable of weathering seismic forces and stand out as material of choice for earthquake prone areas. Timber constructions have high energy efficiency.

Within last few decades, wood has been increasingly used in modern architectural buildings (sports' arenas, residential buildings and bridges) thanks to better understanding of wood as a material, utilization of modern timber construction and high quality connections. Construction elements for contemporary timber constructions are primarily based upon contemporary products such as glued laminated timber and cross laminated timber.

Ljiljana Kozarić, dipl.inž. građ., University of Novi Sad, Faculty of Civil Engineering, Subotica, Kozaračka 2a, Serbia, tel: 024 554 300, e-mail: kozaric@gf.uns.ac.rs
Prof.dr Aleksandar Prokić, dipl.inž. građ., University of Novi Sad, Faculty of Civil Engineering, Subotica, Kozaračka 2a, Serbia, tel: 024 554 300, e-mail: aprokic@eunet.rs
Prof.dr Miroslav Bešević, dipl.inž. građ., University of Novi Sad, Faculty of Civil Engineering, Subotica, Kozaračka 2a, Serbia, tel: 024 554 300
e-mail: miroslav.besevic@gmail.com

Cilj rada jeste da se stručna javnost u Srbiji upozna s primenom unakrsno lameliranih drvenih panela u konstrukcijama, kao i s načinom proračuna pojedinih konstruktivnih elemenata.

2 UNAKRSNO LAMELIRANO DRVO – CLT

Unakrsno lamelirano drvo je moderan proizvod, visoke tehnologije koji je u mnogome unapredio fizičke osobine monolitnog drveta. CLT se proizvodi od kontrolisano sušenih drvenih elemenata podjednake širine - lamela, kojima su uklonjeni nedostaci (npr. čvorovi, smola). Izdvajanjem tih nedostataka i slojevitim, unakrsnim lepljenjem, dobija se materijal koji ima mehaničke karakteristike ujednačenije od mehaničkih karakteristika monolitnog drveta - slika 1.

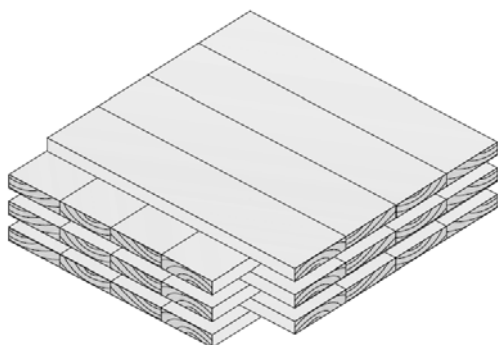

Slika 1. Unakrsno lamelirano drvo [1]
Figure 1. Cross laminated timber [1]

Kao kod šperploča, slojevi mekog drveta postavljaju se tako da vlakna drveta budu međusobno pod pravim uglom. Unakrsno slaganje drveta pruža stabilnost, kao i kod obične šperploče, ali veća debljina slojeva stvara panele koji su dovoljno jaki da budu korišćeni kao konstruktivni elementi, bez potrebe za ojačanjem konstrukcije upotrebom opeke ili betona - slika 2.

Objective of this paper is to introduce possibilities of application of cross laminated timber panels in structures in Serbia, as well as the way the individual structural elements can be calculated.

2 CROSS LAMINATED TIMBER – CLT

Cross laminated timber (CLT) is a sophisticated modern product that greatly improved the physical properties of traditional wood as building material. CLT is made of controlled dried wooden elements – laminates of uniform width, free of defects (knots, resin etc.). By removing all of the defects and cross-gluing the laminates it is possible to produce the material that has more uniform mechanical properties than the traditional wood, Figure 1.

Just like with plywood, the layers of soft wood are positioned in such manner that the wooden grain of adjacent layers are mutually perpendicular. As with plywood, perpendicularly positioned elements create stability; however, greater layer thickness creates panels that are strong enough to be used as a primary structural elements without the need for brick or concrete as reinforcement, Figure 2.



Slika 2. CLT konstrukcija [2]
Figure 2. CLT construction [2]

Poprečni preseki CLT panela sadrže najmanje tri unakrsno zalepljene lamele, a najčešće pet ili sedam. Slojevi s lamelama postavljeni su naizmenično pod pravim uglom, ali se pojedini slojevi mogu i duplirati, stvarajući tako panele s većom nosivošću u potrebnom pravcu - slika 3. Visina lamela u CLT panelima varira od 16 mm do 51 mm, a širina od 60 mm do 240 mm.

Spoljne lamele u zidnim CLT panelima postavljaju se uspravno, paralelno sa silom gravitacije, radi maksimalnog iskorišćenja vertikalne nosivosti panela. Kod podnih i krovnih CLT panela, spoljne lamele postavljaju se paralelno s pravcem dominantnog opterećenja. Spoljašnje površine panela - zbog estetskih zahteva, te zbog zahteva vatrootpornosti i zvučne izolacije - mogu se obložiti gips-kartonskim pločama ili nekom drugom pogodnom oblogom.

A CLT cross section contains a minimum of three cross-glued laminates, but most often five or seven. Alternate layers are mutually perpendicular; however, it is possible to double certain layers so that greater strength can be achieved in a desired direction, Figure 3. Laminate height within a CLT varies from 16 to 51 mm while width varies between 60mm and 240mm.

Outside laminates within a CLT wall are positioned vertically, parallel with the gravitational forces so that vertical potential of the panel can be maximized, while in CLT panels for floor and roof applications are placed parallel with the direction of dominant forces. To meet aesthetic, fireproof, and insulation requirements, the exposed surfaces of the panels can be covered with gypsum or similar appropriate finish.

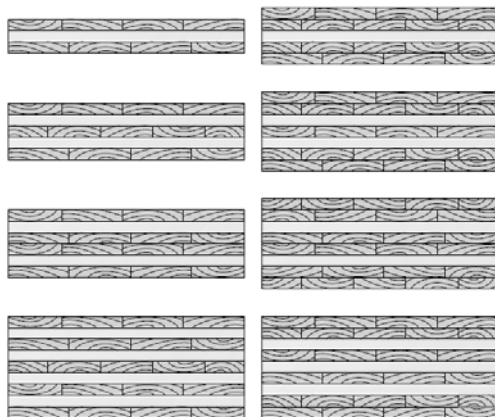

Slika 3. Poprečni preseki CLT panela [3]
Figure 3. CLT Panel cross sections [3]

U Evropi, CLT paneli najčešće se proizvode od četinarara klase čvrstoće C24, vlažnosti $12\pm 2\%$ - [4]. Dimenzije panela zavise od raspoložive tehnologije proizvođača, ali i od načina transporta.

Zidni CLT paneli isporučuju se na gradilište s već formiranim otvorima po projektu. Tipičan zidni CLT panel prikazan je na slici 4.

In Europe, CLT is most often manufactured from conifers grade C24, and moisture content $12\pm 2\%$, [4]. Panel dimensions are dictated by manufacturer technology and mode of transportation.

Wall CLT panels are delivered to a construction site where the wall openings have already been formed according to design. A typical CLT wall panel is shown in Figure 4.

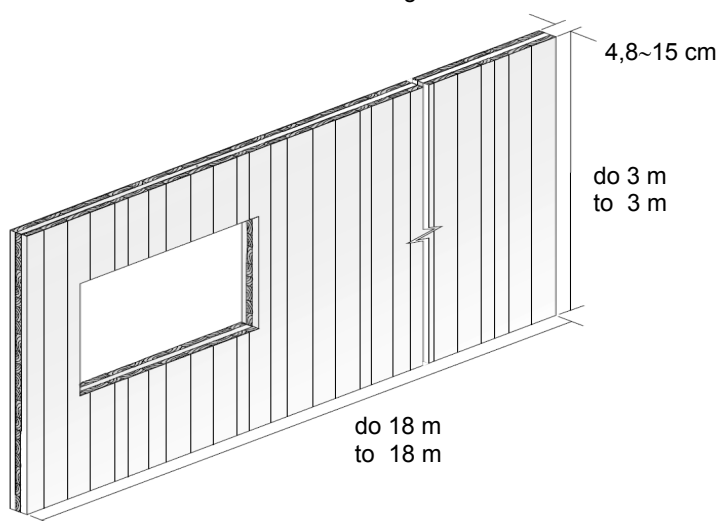

Slika 4. Zidni CLT paneli [3]
Figure 4. Typical Wall CLT panel [3]

Podne i krovne konstrukcije dobijaju se horizontalnim ili kosim slaganjem osnovnih panela. Tipične dimenzije osnovnog podnog i krovnog panela prikazane su na slici 5.

Među najveće evropske proizvođače CLT panela svrstavaju se: KLH (Austrija, UK, Švedska), Binderholz (Austrija), Martinsons (Švedska), Moelven (Norveška), Stora Enso (Austrija), Thoma Holz GmbH (Austrija), FinnForest Merk (Nemačka, UK), HMS (Nemačka).

Svi navedeni proizvođači koriste isti proces proizvodnje, glavna razlika je u dimenzijama CLT panela i u izboru lepka.

Osnovne fizičko-mehaničke karakteristike CLT panela s daskama od četinaru klase čvrstoće C24 (minimalno 90%) i C16 (maksimalno 10%) date su u Tabeli 1.

Floor and roof construction are manufactured by arranging the basic panels in horizontal or angular pattern. Typical dimensions of basic floor or roof panel are depicted in Figure 5. Some of the biggest European CLT panels manufacturers are: KLH (Austria, UK, Sweden), Binderholz (Austria), Martinsons (Sweden), Moelven (Norway), Stora Enso (Austria), Thoma Holz GmbH (Austria), FinnForest Merk (Germany, UK) and HMS (Germany).

All of the above listed manufacturers use the same manufacturing process, while the main differences are panels' dimensions, and the choice of glue.

Basic physical and mechanical properties of CLT panels with planks made out of conifers grade C24 (minimum 90%) and C16 (maximum 10%) are listed in Table 1.

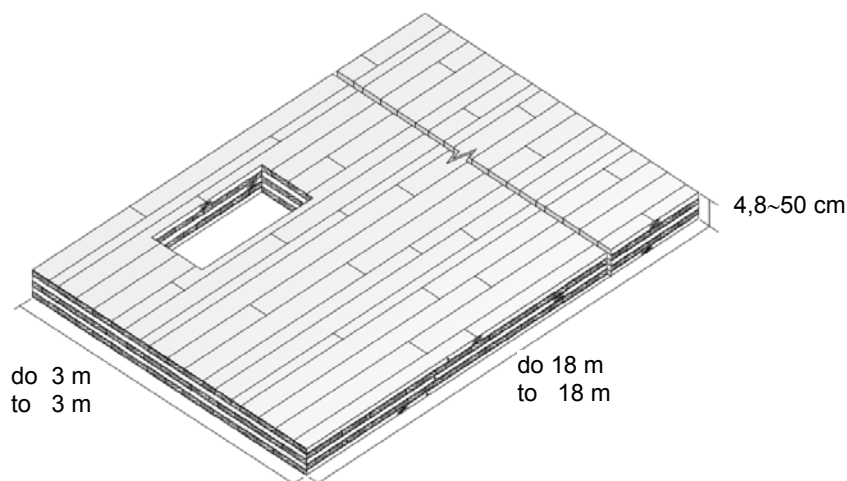

Slika 5. Podni i krovni CLT paneli [3]
Figure 5. Floor and Roof CLT panel [3]

Tabela 1. Osnovne fizičko-mehaničke karakteristike CLT panela [5]
Table 1. Basic physical and mechanical properties of CLT panels [5]

Karakteristične čvrstoće [N/mm ²] / Characteristic strength [N/mm ²]		
Savijanje / Bending	$f_{m,k}$	24
Zatezanje paralelno s vlaknima / Tension along the grain	$f_{t,0,k}$	16,5
Zatezanje upravno na vlakna / Tension across the grain	$f_{t,90,k}$	0,12
Pritisak paralelno s vlaknima / Compression along the grain	$f_{c,0,k}$	24–30
Pritisak upravno na vlakna / Compression across the grain	$f_{c,90,k}$	2,7
Karakteristične krutosti [N/mm ²] / Characteristic stiffness [N/mm ²]		
Srednja vrednost modula E paralelno s vlaknima Median value of modulus of elasticity E along the grain	$E_{0,mean}$	12000
Srednja vrednost modula E upravno s vlaknima Median value of modulus of elasticity E across the grain	$E_{90,mean}$	370
Zapreminska masa [kg/m ³] / Specific weight [kg/m ³]	ρ	480–500
Koeficijent toplotne provodljivosti [W/(mK)] Thermal conductivity coefficient [W/(mK)]	λ	0,13
Dopušteni ugib / Allowable deflection	u_{max}	$l/250$

U svetu, CLT konstrukcije doživele su veliki uspon iz sledećih razloga: neuporedivo su čvršće i imaju bolje statičke osobine od monolitnog drveta, nemaju sklonost ka uvijanju, pojava napuklina svedena je na minimum, velika požarna otpornost, visoka otpornost na potres.

Upotrebom CLT panela smanjuje se vreme izgradnje, jer se drveni elementi isporučuju kao prefabrikovani zidovi ili moduli, koji se zatim brzo uklapaju na gradilištu. Izgradnja CLT konstrukcije je oko 30% brža u poređenju sa odgovarajućom betonskom konstrukcijom. Takođe, drvo je „suv“ građevinski materijal, njemu ne treba vreme da se osuši ili očvrsne, kao što je to slučaj s betonom ili opekom. Za CLT panele koristi se mekano drvo koje raste brzo i kog ima u izobilju, pa je i cena CLT konstrukcija niža od 5 do 10% od odgovarajućih betonskih ili čeličnih [6].

Drvo je obnovljiv izvor, što je velika prednost, kao i to što u toku rasta vezuje velike količine ugljen-dioksida. Za proizvodnju tone betona potrebno je pet puta, za čelik 24 puta, dok je za tonu aluminijuma potrebno 126 puta više energije nego za proizvodnju materijala od drveta. Drvo je i mnogo bolji izolator i to pet puta bolji od betona i čak 350 puta bolji nego što je to čelik [7].

3 PRIMERI IZVEDENIH CLT KONSTRUKCIJA

3.1 Stambena zgrada Forte u Melburnu

Zgrada Forte trenutno je najviša stambena zgrada izgrađena od drveta na svetu. Projektovala ju je i izgradila kompanija Lend Lease 2013. godine. Visoka je 32,17 metara. U prizemlju su poslovni prostori, a na spratovima ima 23 stana - slika 6.



Worldwide, CLT became greatly popular for the following reasons: CLT is much stronger with far more superior mechanical properties than traditional wood, no bending tendency, minimal fractures appearance, high resistance to fire, and resilience to earthquakes.

Since CLT is delivered to construction site in prefabricated or modular form it takes on average 30% less time to complete CLT than a comparable concrete or brick and mortar project. Contributing to the speed of completion is also the fact that unlike concrete, timber is “dry” building material that does not require either the time to dry, or the time to cure and achieve its final strength. Fast growing easily accessible softwood keeps the price of CLT 5 to 10% lower than the competing concrete or steel construction [6].

Timber's great advantage is that it is a renewable resource, and in the process of growth trees absorb great amount of carbon dioxide. To produce one ton of concrete, steel or aluminium it takes 5, 24 and 126 times more energy respectively than for the production of timber. Timber is 5 times better insulator than concrete and up to 350 times better than steel [7].

3 EXAMPLES OF CLT APPLICATIONS

3.1 Apartment building Forte in Melbourne, Australia

Forte is currently the tallest residential timber building in the world. The design and construction has been done in 2013 by Lend Lease. The apartment building is 32,17m tall. At the ground floor there are commercial spaces, and 23 apartments in the above floors, Figure 6.



Slika 6. Zgrada Forte u Melburnu
Figure 6. Forte Residential Building in Melbourne, Australia

Osnovni konstruktivni elementi su drveni zidni paneli i podne ploče. Za izgradnju je bilo potrebno 759 CLT panela, odnosno 485 tona drvene građe. Zgrada Forte je prva stambena zgrada sertifikovana s pet zvezda programa Green Star As Built u Australiji.

Drvena građa u ovom objektu skladišti 761 tonu ugljenika, a odabirom CLT konstrukcije količina ugljen-dioksida u atmosferi se smanjila ukupno za oko 1 451 tonu, jer bi se pri izgradnji sličnog objekta od betona ili čelika, u atmosferu ispuštao dodatni ugljen-dioksid. Ta

Basic design elements are wooden wall and floor panels. It took 759 CLT panels, or 485 tons of wooden material for construction. Forte residential building is the first Five Star Green Star as built rating in Australia. The wooden material in this building stores 761 ton of carbon, and by choosing CLT over concrete or steel the total amount of carbon dioxide released in the atmosphere has been reduced by 1,451 tons. This amount represents the equivalent of the carbon dioxide released by 345 cars during one year [8].

količina ugljen-dioksida predstavlja 345 automobila manje na ulici u toku jedne godine [8].

3.2 Stambena zgrada Stadthaus u Londonu

Zgrada Stadthaus sagrađena je 2008. godine u Londonu i pune dve godine bila je najviša drvena stambena zgrada na svetu. Ovu devetospratnicu projektovala je kompanija Waugh Thistleton Architects. Podovi, plafoni, kućište lifta i stepeništa izrađeni su u potpunosti od drveta - slika 7.



Slika 7. Zgrada Stadthaus u Londonu
Figure 7. Stadthaus Residential Building in London, UK

Korisna površina stambene zgrade jeste 2.352 m² i za izgradnju bilo je potrebno 950 m³ CLT panela. Zidni paneli bili su debljine 128 mm, a podni - 146 mm. Za izgradnju jednog sprata bilo je potrebno tri dana. U poređenju s betonskom konstrukcijom, projektanti su izborom CLT konstrukcije uštedeli dvadeset dve nedelje gradnje, što predstavlja uštedu u vremenu od oko 30%.

Drvo ugrađeno u Stadthaus čuva oko 186 tona ugljenika, dok bi se za čelik i beton koji se koriste u konvencionalnom građevinarstvu, za sličnu građevinu, u atmosferu isпустиo oko 137 tona ugljen-dioksida u procesu proizvodnje. Dakle, ovakav način gradnje smanjio bi količinu ugljen-dioksida u atmosferi za oko 323 tone [9].

3.3 Srednja škola u Noriču UK

Objekat se nalazi u Noriču i trenutno je najveća CLT konstrukcija u Ujedinjenom kraljevstvu. Sagrađena je krajem 2009. godine. Glavni arhitekta bio je Sheppard Robson. Korisna površina objekta iznosi 9.500 m², a za izgradnju bilo je potrebno 3.065 m³ CLT panela. Kompletna konstrukcija ovog trospratnog objekta izgrađena je za šesnaest nedelja. Fiskulturnu salu u sklopu škole od 600 m² (slika 8) montirala su četiri radnika za četiri dana. Za montažu jednog zidnog CLT panela dimenzije 3 m x 6 m debljine 15 cm, bilo je potrebno samo tri sata.

3.2 Stadthaus Residential Building in London, UK

Stadthaus Residential building was built in 2008 and for full two year was the world's tallest timber residential building. This nine story building has been designed by Waugh Thistleton Architects. Floors, ceilings, elevator shaft and stair flights were built completely out of timber, Figure 7.

Buildings used area is 2,352 m² and it took 950 m³ of CLT panels for construction. Wall panels' thickness varies from 128 mm to 146 mm. It took three days for completion of one story. Compared to a concrete building construction, the CLT method is 22 weeks faster, which amounts to total time reduction of about 30%.

The amount of wood in Stadthaus stores 186 tons of carbon, while for construction of conventional steel or concrete building of this size 137 tons of carbon dioxide would have been released in the atmosphere. As a result, CLT method reduces the total carbon dioxide footprint for 323 tons [9].

3.3 High School in Norwich, UK

The School is located in Norwich and currently is the largest CLT construction in the United Kingdom. It was built in 2009. The lead architect was Sheppard Robson. Building's used area is 9,500 m², and it took 3,065 m³ of CLT panels for its completion. The construction of this three story building was completed in 16 weeks. The 600 m² gymnasium within the school building was assembled by 4 workers in 4 days, Figure 8. It takes only 3 hours for the installation of one 3 m by 6 m wall CLT panel.



Slika 8. Srednja škola u Noriču UK
Figure 8. High School in Norwich, UK

Zidovi i podovi su CLT paneli, dok su gredni nosači izvedeni od lepljenog-lameliranog drveta - slika 6. Prosečan raspon međuspratnih CLT ploča iznosi 7,5 metara, sa osnovnom frekvencijom oscilovanja od 8 Hz - slika 9.

CLT panels were used for the walls and floors, while the girders were built from glued laminated timber, Figure 9. The average span of the floor CLT panels is 7,5 meters with base frequency of 8 Hz, Figure 17.



Slika 9. Izgradnja srednje škole u Noriču UK
Figure 9. Construction of High School in Norwich, UK

4 DIMENZIONISANJE ELEMENATA CLT KONSTRUKCIJA

Proizvođači CLT panela u Evropi nemaju jedinstveni analitički pristup prilikom dimenzionisanja elemenata CLT konstrukcija. Za dimenzionisanje međuspratnih i krovnih konstrukcija od CLT panela najčešće se koriste [1] [10]: Gamma metod (Evrokod 5), K-metod (Teorija kompozita), Kreuzinger-ova analogija i Uprošćen postupak proračuna.

Zidni CLT paneli dimenzionišu se kao pritisnuti štapovi složenog preseka, spojeni mehaničkim spojnim sredstvima (Evrokod 5).

4 DESIGNING THE ELEMENTS FOR CLT CONSTRUCTION

CLT manufacturers in Europe do not have unified analytical approach for the design of elements for CLT construction. The following methods are most frequently used for the floor and roof CLT design, [1] [10]: Gamma Method (Eurocode 5), K – Method (Composite theory), Kreuzinger Analogy and Simplified Design Methods.

CLT wall panels are calculated as mechanically joined compressed columns with complex cross section (Eurocode 5).

4.1 Gamma metod

Gamma metod zasnovan je na Aneksu B Evrokoda 5 (EN 1995-1-1:2004) [11] koji je razvijen za gredne nosače složenog poprečnog preseka, spojene mehaničkim spojnim sredstvima krutosti k postavljenim na jednakim rastojanjima s . Prilikom proračuna CLT panela, uzimaju se u obzir samo podužne lamele to jest lamele u pravcu delovanja opterećenja. One se modeliraju kao gredni nosači koji su povezani „imaginarnim“ mehaničkim spojnim sredstvima čija je krutost jednaka modulu smicanja upravno na vlakna poprečnih lamela. Smicanje podužnih lamela zanemaruje se ako je odnos raspona i visine lamele ≥ 30 .

Ovaj metod proračuna prikladan je za slobodno oslonjene međuspratne i krovne CLT panele sa 3 ili 5 lamela.

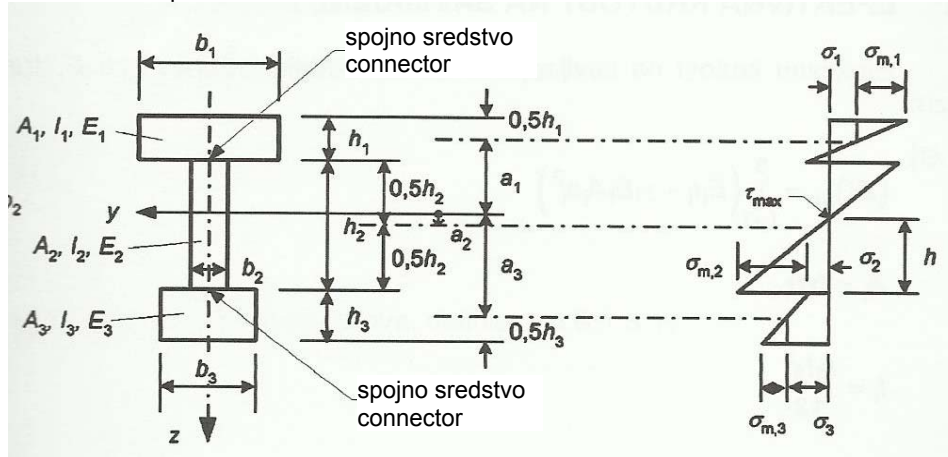

Legenda / Legend:

- (1) razmak / span s_1 modul pomerljivosti / displacement modulus K_1 opterećenje / load F_1
 (2) razmak / span s_2 modul pomerljivosti / displacement modulus K_2 opterećenje / load F_2

Slika 10. Model CLT panela sa 5 lamela [11]
 Figure 10. CLT Panel with 5 laminates [11]

Efektivna krutost na savijanje računa se prema izrazu

Effective stiffness can be calculated based on the following expression:

$$(EI)_{ef} = \sum_{i=1}^3 (E_i I_i + \gamma_i E_i A_i a_i^2) \quad (1)$$

gde su simboli definisani na slici 10, a γ predstavlja meru efikasnosti veze i ima vrednost od 0 do 1. Kad nema spojnog sredstva u vezi $\gamma = 0$ a kod potpuno krute veze (potpunog sprezanja) $\gamma = 1$. Kod CLT panela $\gamma = 0,85 \div 0,99$.

where the symbols have been defined in Figure 10, and γ represent the effectiveness of the connection with its value ranging from 0 to 1. For the connection with no connectors, $\gamma = 0$, while for fully fixed connection (coupling) $\gamma = 1$. For CLT panels $\gamma = 0,85 \div 0,99$

U Evrokodu 5 γ definisana je kao

Eurocode 5 defines γ as:

$$\gamma_i = \left[1 + \frac{\pi^2 E_i A_i s_i}{K_i l^2} \right]^{-1} \quad (2)$$

za $i=1$ i $i=3$

for $i=1$ and $i=3$

Uzimajući u obzir da je krutost „imaginarnih“ mehaničkih spojnih sredstava jednaka modulu smicanja upravno na vlakna poprečnih lamela

If taken into consideration that the stiffness of “imaginary” mechanical connectors is equal to the shear modulus along the grain of lateral laminates then:

$$\frac{s_i}{K_i} = \frac{\bar{h}_i}{G_R \cdot b} \quad (3)$$

gde je b širina panela (obično 1 m)
 \bar{h}_i visina poprečne lamele

where b is width of a panel (usually 1 m)
 \bar{h}_i is height of the lateral laminate

G_R modul smicanja upravno na vlakna poprečnih lamela

G_R is shear modulus along the grain of lateral laminates

za CLT panele dobija se da je

Expression for CLT panels is given as:

$$\gamma_i = \left[1 + \frac{\pi^2 E_i A_i}{l^2} \cdot \frac{\bar{h}_i}{G_R \cdot b} \right]^{-1} \quad (4)$$

za $i=1$ i $i=3$

for $i=1$ and $i=3$

Normalni napon računa se kao

Normal stress can be calculated as

$$\sigma_{i \max} = \sigma_{i \text{ global}} + \sigma_{i \text{ local}} \quad (5)$$

gde je

where

$$\sigma_{i \text{ global}} = \frac{\gamma_i E_i a_i M}{(EI)_{ef}} \quad (6)$$

$$\sigma_{i \text{ local}} = \frac{0,5 E_i h_i M}{(EI)_{ef}}$$

4.2 K - metod (Blass&Fellmoser)

Prilikom proračuna ovom metodom, u obzir se uzima krutost svih lamela. Modul elastičnosti poprečnih lamela računa se kao

4.3 K - method (Blass&Fellmoser)

This design method includes the stiffness of all laminates. Modulus of elasticity of lateral laminates can be calculated as:

$$E_{90} = E_0 / 30 \quad (7)$$

Princip proračuna sličan je proračunu šperploča. Efektivne vrednosti napona i krutosti dobijaju se pomoću koeficijenta k_i - Tabela 2.

The method is similar to the design method for plywood. The values for stress and stiffness can be calculated by using the coefficient k_i , Table 2.

Tabela 2. Efektivne vrednosti napona i krutosti CLT panela [12]
Table 2. Normal Stress and Effective Stiffness Values [12]

Opterećenje Load	Pravac vlakana Grain direction	Efektivni napon Normal Stress	Efektivna krutost Effective Stiffness
Opterećenje normalno na ravan panela Load perpendicular to a panel			
Savijanje Bending	Paralelno s vlaknima Along the grain	$f_{m,0,ef} = f_{m,0} \cdot k_1$	$E_{m,0,ef} = E_0 \cdot k_1$
	Upravno na vlakna Across the grain	$f_{m,90,ef} = f_{m,0} \cdot k_2 \cdot a_m / a_{m-2}$	$E_{m,90,ef} = E_0 \cdot k_2$

Opterećenje u ravni panela Load in the plane of a panel			
Savijanje Bending	Paralelno s vlaknima Along the grain	$f_{m,0,ef} = f_{m,0} \cdot k_3$	$E_{m,0,ef} = E_0 \cdot k_3$
	Upravno na vlakna Across the grain	$f_{m,90,ef} = f_{m,0} \cdot k_4$	$E_{m,90,ef} = E_0 \cdot k_4$
Zatezanje Tension	Paralelno s vlaknima Along the grain	$f_{t,0,ef} = f_{t,0} \cdot k_3$	$E_{t,0,ef} = E_0 \cdot k_3$
	Upravno na vlakna Across the grain	$f_{t,90,ef} = f_{t,0} \cdot k_4$	$E_{t,90,ef} = E_0 \cdot k_4$
Pritisak Compression	Paralelno s vlaknima Along the grain	$f_{c,0,ef} = f_{c,0} \cdot k_3$	$E_{c,0,ef} = E_0 \cdot k_3$
	Upravno na vlakna Across the grain	$f_{c,90,ef} = f_{c,0} \cdot k_4$	$E_{c,90,ef} = E_0 \cdot k_4$

Koeficijenti k_i definisani su u zavisnosti od opterećenja - Tabela 3.

Depending on the load coefficients k_i are defined in Table 3.

Tabela 3. Vrednosti koeficijenata k_i [12][3]

Table 3. Coefficients k_i Values [12][3]

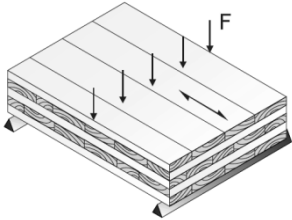
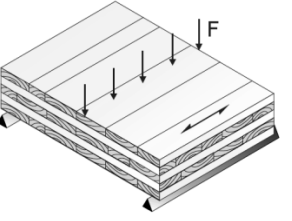
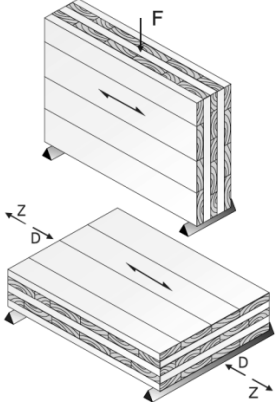
Opterećenje / Load	k_i
	$k_1 = 1 - \left(1 - \frac{E_{90}}{E_0}\right) \cdot \frac{a_{m-2}^3 - a_{m-4}^3 + \dots \pm a_1^3}{a_m^3}$
	$k_2 = \frac{E_{90}}{E_0} + \left(1 - \frac{E_{90}}{E_0}\right) \cdot \frac{a_{m-2}^3 - a_{m-4}^3 + \dots \pm a_1^3}{a_m^3}$
	$k_3 = 1 - \left(1 - \frac{E_{90}}{E_0}\right) \cdot \frac{a_{m-2} - a_{m-4} + \dots \pm a_1}{a_m}$

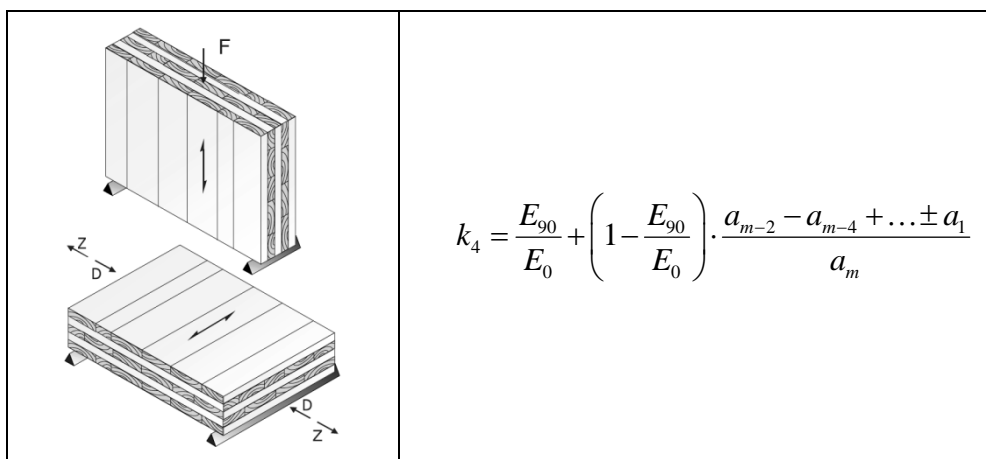

$$k_4 = \frac{E_{90}}{E_0} + \left(1 - \frac{E_{90}}{E_0}\right) \cdot \frac{a_{m-2} - a_{m-4} + \dots \pm a_1}{a_m}$$

Način određivanja rastojanja a CLT panela s pet lamela ($m = 5$) prikazan je na slici 11.

Figure 11. Depicts the method to determine spans a CLT panels with 5 laminates ($m = 5$).

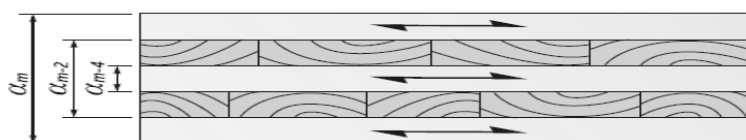

Slika 11. CLT panel sa 5 lamela [3]
Figure 11. CLT Panel with 5 laminates [3]

Efektivna krutost na savijanje od opterećenja upravno na ravan panela jeste:

- paralelno s vlaknima

Effective bending stiffness perpendicular to the panel can be calculated as:

- along the grain

$$(EI)_{ef} = E_0 \cdot \frac{b \cdot a_m^3}{12} \cdot k_1 \quad (8)$$

- upravno na vlakna

- across the grain

$$(EI)_{ef} = E_0 \cdot \frac{b \cdot a_m^3}{12} \cdot k_2 \quad (9)$$

gde b predstavlja širinu panela opterećenog upravno na svoju ravan.

where b represents the width of the panel perpendicular to its own plane.

Normalni napon savijanja od opterećenja upravno na ravan panela jeste:

Normal bending stress from the load perpendicular to the plane of the panel can be calculated as:

- paralelno s vlaknima

- along the grain

$$\sigma_m = \frac{M}{(EI)_{ef}} \cdot E_0 \cdot \frac{a_m}{2} \quad (10)$$

- upravno na vlakna

- across the grain

$$\sigma_m = \frac{M}{(EI)_{ef}} \cdot E_0 \cdot \frac{a_{m-2}}{2} \quad (11)$$

4.3 Kreuzinger-ova analogija

Kreuzinger pri proračunu uzima različite module elastičnosti i module smicanja podužnih i poprečnih lamela. Smicanje podužnih lamela se ne zanemaruje. Modul elastičnosti poprečnih lamela računa se po izrazu (7). Kreuzinger-ova analogija nije ograničena brojem lamela u panelu.

Ovom analogijom, CLT panel deli se u dve virtualne grede A i B - slika 12.

4.3 Kreuzinger Analogy

Design according to Kreuzinger considers different modules of elasticity and shear for longitudinal and lateral laminates. Longitudinal shear of laminates is also considered. Modulus of elasticity of lateral laminates can be calculated by using expression (7). Number of laminates is not a limiting factor in Kreuzinger Analogy.

This method divides the CLT panel into two virtual beams A and B as in Figure 12.

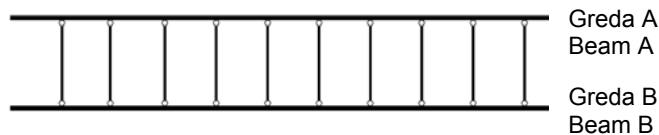

Slika 12. Kreuzinger-ova analogija [1]
Figure 12. Kreuzinger Analogy [1]

Efektivna krutost

Effective stiffness

$$(EI)_{ef} = (EI)_A + (EI)_B = \sum_{i=1}^n E_i \cdot b_i \frac{h_i^3}{12} + \sum_{i=1}^n E_i \cdot A_i \cdot Z_i^2 \quad (12)$$

gde je b_i širina panela (obično 1 m)

where b_i is width of a panel (usually 1 m)

h_i visina lamele

h_i is height of the laminate

Z_i rastojanje od težišta lamele do neutralne ose

Z_i is the distance from the centroid of the laminate to the neutral axis, Figure 13.

- slika 13.

Figure 13.

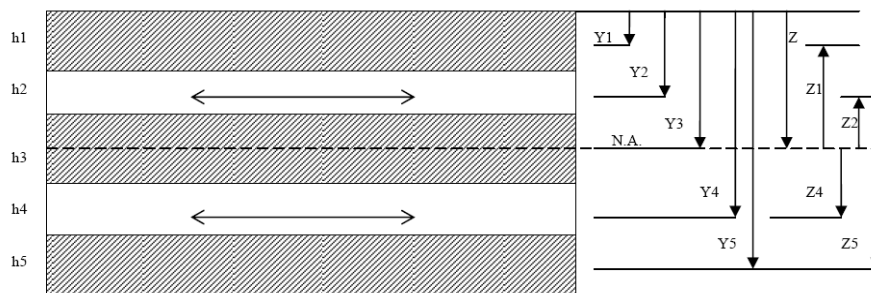

Slika 13. Rastojanja z_i kod CLT panela sa 5 lamela [10]

Figure 13. Distance z_i with CLT panels with 5 laminates [10]

4.4 Proračun zidnih CLT panela

Zidni CLT paneli dimenzionišu se kao pritisnuti štapovi složenog preseka, spojeni mehničkim spojnim sredstvima. Postupak proračuna izložen je u Aneksu C Evrokoda 5 (EN 1995-1-1:2004) [11].

Metod proračuna zasnovan je na sledećim pretpostavkama:

- elementi su sistema proste grede, dužine l
- elementi složenog preseka idu kontinualno duž štapa.

Efektivnu vitkost treba uzeti prema izrazu

4.4 Design Method for CLT Wall Panels

CLT wall panels are calculated as mechanically joined compressed columns with complex cross section. Design method is presented in annex C of Eurocode 5 (EN 1995-1-1:2004) [11].

The method is based upon following assumptions:

- The elements are simple beams with length l ,
- The elements with the complex cross section run longitudinally with the member.

Effective slenderness shall be calculated using the following expression:

$$\lambda_{ef} = l \sqrt{\frac{A_{tot}}{I_{ef}}} \quad (13)$$

gde je A_{tot} ukupna površina poprečnog preseka panela
 l visina panela (dužina izvijanja)
 I_{ef} efektivni momenat inercije

where A_{tot} the total area of the cross section of the panel
 l the height of the panel (bending length)
 I_{ef} the effective moment of inertia

Efektivni momenat inercije dobija se pomoću sledećeg izraza

Effective moment of inertia shall be calculated based on the following expression:

$$I_{ef} = \frac{(EI)_{ef}}{E_{mean}} \quad (14)$$

gde je

where

$(EI)_{ef}$ efektivna krutost
 E_{mean} srednja vrednost modula elastičnosti vertikalnih lamela

$(EI)_{ef}$ effective stiffness
 E_{mean} median value of modulus of elasticity of the vertical laminates

Efektivna vitkost λ_{ef} uvrštava se u izraz 6.21 Evrokoda 5, a proračun nosivosti CLT panela vrši se po poglavlju 6 Evrokoda 5.

Effective slenderness λ_{ef} is used in expression 6.21 of Eurocode 5 while bearing capacity of a CLT panel shall be calculated following chapter 6 of Eurocode 5.

5 PRIMER

5 EXAMPLE

Sračunati efektivnu krutost $(EI)_{ef}$ slobodno oslonjenog podnog CLT panela dužine 4,5 metara, a širine 1 metar. Poprečni presek panela prikazan je na slici 14. Ukupna visina panela je 14 centimetara. Opterećenje deluje upravno na ravan panela paralelno s vlaknima spoljnih lamela [3].

Calculate the effective stiffness $(EI)_{ef}$ of the simply supported CLT floor panel 4,5m long and 1m wide. Panel's cross section is depicted on Figure 14. The total height of the panel is 14 centimetres. The load is acting perpendicularly to the panel and along the grain of the exterior laminates [3].

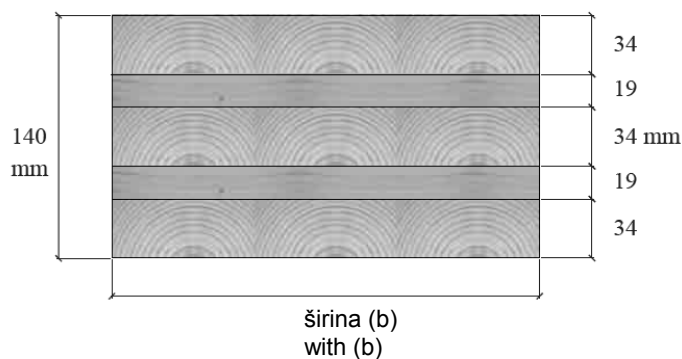

Slika 14. Geometrijske karakteristike panela
 Figure 14. Geometric characteristics of the panel

Fizičko-mehaničke karakteristike podužnih lamela:

Physical and mechanical properties of the longitudinal laminates:

$$E_0 = 11000 \text{ MPa}$$

$$E_{90} \approx \frac{E_0}{30} = \frac{11000}{30} = 367 \approx 370 \text{ MPa}$$

$$G_0 \approx \frac{E_0}{16} = \frac{11000}{16} = 688 \approx 690 \text{ MPa}$$

$$G_R \approx \frac{G_0}{10} = \frac{690}{10} = 69 \text{ MPa}$$

Fizičko-mehaničke karakteristike poprečnih lamela:

Physical and mechanical properties of the lateral laminates:

$$E_0 = 9000 \text{ MPa}$$

$$E_{90} \approx \frac{E_0}{30} = \frac{9000}{30} = 300 \text{ MPa}$$

$$G_0 \approx \frac{E_0}{16} = \frac{9000}{16} = 563 \approx 560 \text{ MPa}$$

$$G_R \approx \frac{G_0}{10} = \frac{560}{10} = 56 \text{ MPa}$$

Odnos raspona i visine lamele CLT panela jeste

Ratio of the span to the height of the panel is:

$$\frac{l}{h} = \frac{450}{14} = 32 > 30$$

pa se smicanje podužnih lamela zanemaruje.

Thus the shear of the longitudinal laminates can be neglected.

5.1 Gamma metod

5.1 Gamma method

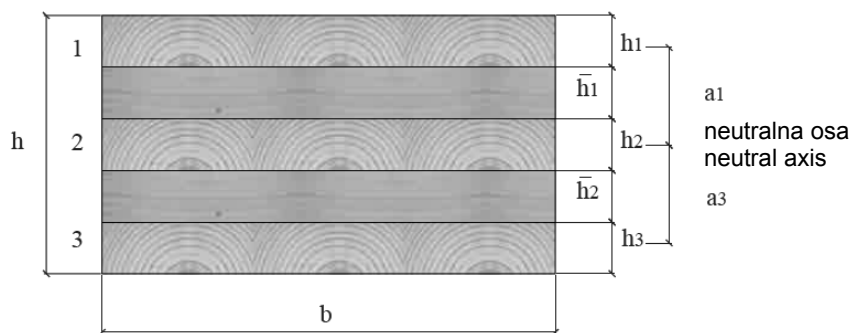

Slika 15. Geometrijske karakteristike panela (Gamma metod)
Figure 15. Geometric characteristics of the panel (Gamma method)

$$h_1 = h_2 = h_3 = 34 \text{ mm} \quad \bar{h}_1 = \bar{h}_2 = 19 \text{ mm} \quad h = 140 \text{ mm}$$

$$E_1 = E_2 = E_3 = 11000 \text{ MPa}$$

$$G_R = 56 \text{ MPa}$$

Efektivna krutost računa se po jednačini (1)

The effective stiffness shall be calculated by using the expression (1):

$$(EI)_{ef} = \sum_{i=1}^3 (E_i I_i + \gamma_i E_i A_i a_i^2)$$

Ako su

If

$$\gamma_1 = \gamma_3 = \gamma \quad i / \text{ and } \quad \gamma_2 = 1$$

dobijamo

then

$$(EI)_{ef} = (E_1 I_1 + \gamma_1 E_1 A_1 a_1^2) + (E_2 I_2) + (E_3 I_3 + \gamma_3 E_3 A_3 a_3^2)$$

gde je

where

$$A_1 = A_3 = A$$

$$E_1 = E_2 = E_3 = E$$

$$I_1 = I_2 = I_3 = I = \frac{bh_1^3}{12}$$

$$a_2 = 0$$

$$a_1 = a_3 = a = \frac{h_1}{2} + \bar{h}_1 + \frac{h_2}{2} = \frac{h_2}{2} + \bar{h}_2 + \frac{h_3}{2}$$

pa se za efektivnu krutost dobija

Then the effective stiffness is:

$$(EI)_{ef} = EI \left[3 + \frac{2\gamma A a^2}{I} \right]$$

Ako je

If

$$\gamma = \frac{1}{\left[1 + \frac{\pi^2 EA}{l^2} \cdot \frac{\bar{h}}{G_R \cdot b} \right]} = \frac{1}{1 + \frac{\pi^2 11000 \cdot (1000 \cdot 34)}{4500^2} \cdot \frac{19}{56 \cdot 1000}} = 0,9418$$

$$A = bh = 1000 \cdot 34 = 34000 \text{ mm}^2$$

$$a = a_1 = a_3 = \frac{h_1}{2} + \bar{h}_1 + \frac{h_2}{2} = \frac{h_2}{2} + \bar{h}_2 + \frac{h_3}{2} = \frac{34}{2} + 19 + \frac{34}{2} = 53 \text{ mm}$$

$$I = \frac{bh_1^3}{12} = \frac{1000 \cdot 34^3}{12} = 3,275 \times 10^6 \text{ mm}^4$$

dobijamo

Then

$$(EI)_{ef} = 11000 \cdot 3,275 \times 10^6 \left[3 + \frac{2 \cdot 0,9418 \cdot 34000 \cdot 53^2}{3,275 \times 10^6} \right] = 2087 \times 10^9 \text{ Nmm}^2$$

5.2 K - metod (Blass&Fellmoser)

5.2 K - method (Blass&Fellmoser)

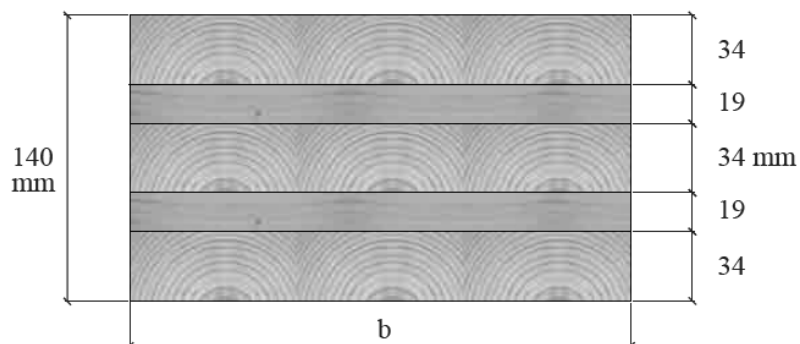

Slika 16. Geometrijske karakteristike panela (K-metod)
Figure 16. Geometric characteristics of the panel (K- method)

$$E_0 = 11000 \text{ MPa}$$

$$E_{90} = 300 \text{ MPa}$$

Iz Tabele 3 dobijamo

From Table 3 we get:

$$a_m = a_5 = 140 \text{ mm}$$

$$a_{m-2} = a_3 = 19 + 34 + 19 = 72 \text{ mm}$$

$$a_{m-4} = a_1 = 34 \text{ mm}$$

$$k_1 = 1 - \left(1 - \frac{E_{90}}{E_0}\right) \cdot \frac{a_3^3 - a_1^3}{a_5^3} = 1 - \left(1 - \frac{300}{11000}\right) \cdot \left(\frac{72^3 - 34^3}{140^3}\right) = 0,8816$$

a iz Tabele 2

And from Table 2

$$E_{m,0,ef} = E_0 \cdot k_1 = 11000 \cdot 0,8816 = 9698 \text{ MPa}$$

pa je efektivna krutost CLT panela širine $b = 1000 \text{ mm}$

Finally the effective stiffness of the CLT panel with width $b = 1000 \text{ mm}$

$$(EI)_{ef} = 9698 \cdot \frac{1000 \cdot 140^3}{12} = 2218 \times 10^9 \text{ Nmm}^2$$

5.3 Kreuzinger-ova analogija

5.3 Kreuzinger Analogy

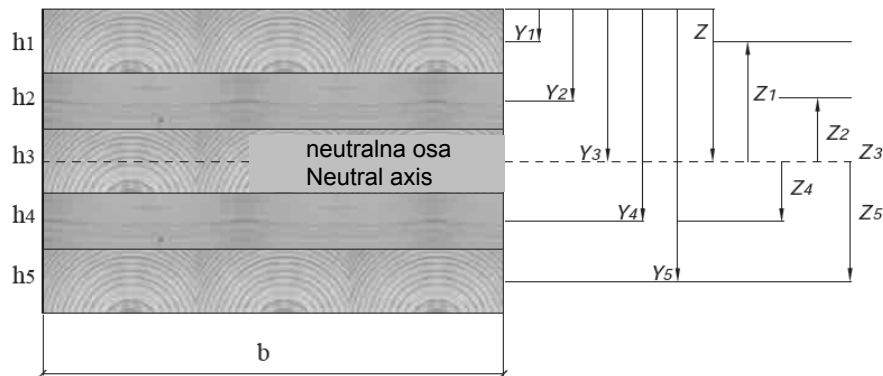

Slika 17. Geometrijske karakteristike panela (Kreuzinger-ova analogija)
Figure 17. Geometric characteristics of the panel (Kreuzinger Analogy)

$h_1 = 34 \text{ mm}$	$E_0 = 11000 \text{ MPa}$	$E_{90} = 370 \text{ MPa} (\approx 11000 / 30)$
$h_2 = 19 \text{ mm}$	$E_0 = 9000 \text{ MPa}$	$E_{90} = 300 \text{ MPa} (\approx 9000 / 30)$
$h_3 = 34 \text{ mm}$	$E_0 = 11000 \text{ MPa}$	$E_{90} = 370 \text{ MPa} (\approx 11000 / 30)$
$h_4 = 19 \text{ mm}$	$E_0 = 9000 \text{ MPa}$	$E_{90} = 300 \text{ MPa} (\approx 9000 / 30)$
$h_5 = 34 \text{ mm}$	$E_0 = 11000 \text{ MPa}$	$E_{90} = 370 \text{ MPa} (\approx 11000 / 30)$

$$h = h_1 + h_2 + h_3 + h_4 + h_5 = 140 \text{ mm}$$

$$b = 1000 \text{ mm}$$

Efektivna krutost dobija se iz jednačine (12)

The effective stiffness shall be calculated by using the expression (12)

$$(EI)_{ef} = (EI)_A + (EI)_B = \sum_{i=1}^n E_i \cdot b_i \frac{h_i^3}{12} + \sum_{i=1}^n E_i \cdot A_i \cdot Z_i^2$$

Položaj neutralne ose Z

The location of the neutral axis Z is:

$$Z = \frac{\sum_{i=1}^n (E_i A_i) \cdot Y_i}{\sum_{i=1}^n (E_i A_i)}$$

$$E_1 A_1 = E_1 \cdot b \cdot h_1 = 11000 \cdot 1000 \cdot 34 = 3,74 \times 10^8 \text{ N}$$

$$E_2 A_2 = E_2 \cdot b \cdot h_2 = 300 \cdot 1000 \cdot 19 = 5,7 \times 10^6 \text{ N}$$

$$E_3 A_3 = E_3 \cdot b \cdot h_3 = 11000 \cdot 1000 \cdot 34 = 3,74 \times 10^8 \text{ N}$$

$$E_4 A_4 = E_4 \cdot b \cdot h_4 = 300 \cdot 1000 \cdot 19 = 5,7 \times 10^6 \text{ N}$$

$$E_5 A_5 = E_5 \cdot b \cdot h_5 = 11000 \cdot 1000 \cdot 34 = 3,74 \times 10^8 \text{ N}$$

$$\sum_{i=1}^5 (E_i A_i) = 11,334 \times 10^8 \text{ N}$$

$$Y_1 = \frac{h_1}{2} = \frac{34}{2} = 17 \text{ mm}$$

$$Y_2 = h_1 + \frac{h_2}{2} = 34 + \frac{19}{2} = 43,5 \text{ mm}$$

$$Y_3 = h_1 + h_2 + \frac{h_3}{2} = 34 + 19 + \frac{34}{2} = 70 \text{ mm}$$

$$Y_4 = h_1 + h_2 + h_3 + \frac{h_4}{2} = 34 + 19 + 34 + \frac{19}{2} = 96,5 \text{ mm}$$

$$Y_5 = h_1 + h_2 + h_3 + h_4 + \frac{h_5}{2} = 34 + 19 + 34 + 19 + \frac{34}{2} = 123 \text{ mm}$$

$$E_1 A_1 Y_1 = 3,74 \times 10^8 \cdot 17 = 6,358 \times 10^9 \text{ Nmm}$$

$$E_2 A_2 Y_2 = 5,7 \times 10^6 \cdot 43,5 = 2,48 \times 10^8 \text{ Nmm}$$

$$E_3 A_3 Y_3 = 3,74 \times 10^8 \cdot 70 = 2,618 \times 10^{10} \text{ Nmm}$$

$$E_4 A_4 Y_4 = 5,7 \times 10^6 \cdot 96,5 = 5,501 \times 10^8 \text{ Nmm}$$

$$E_5 A_5 Y_5 = 3,74 \times 10^8 \cdot 123 = 4,6 \times 10^{10} \text{ Nmm}$$

$$\sum_{i=1}^5 (E_i A_i) \cdot Y_i = 7,934 \times 10^{10} \text{ Nmm}$$

pa je

then

$$Z = \frac{\sum_{i=1}^5 (E_i A_i) \cdot Y_i}{\sum_{i=1}^5 (E_i A_i)} = \frac{7,934 \times 10^{10}}{11,334 \times 10^8} = 70 \text{ mm}$$

$$Z_1 = Z - \frac{h_1}{2} = 70 - \frac{34}{2} = 53 \text{ mm}$$

$$Z_2 = Z - h_1 - \frac{h_2}{2} = 70 - 34 - \frac{19}{2} = 26,5 \text{ mm}$$

$$Z_3 = Z - h_1 - h_2 - \frac{h_3}{2} = 70 - 34 - 19 - \frac{34}{2} = 0 \text{ mm}$$

$$Z_4 = -Z_2 = -26,5 \text{ mm}$$

$$Z_5 = -Z_1 = -53 \text{ mm}$$

Proračun krutosti virtuelne grede A

Stiffness calculation for the virtual beam A

$$(EI)_A = \sum_{i=1}^n E_i \cdot b_i \frac{h_i^3}{12}$$

$$E_1 b \frac{h_1^3}{12} = 11000 \cdot 1000 \frac{34^3}{12} = 3,603 \times 10^{10} \text{ Nmm}^2$$

$$E_2 b \frac{h_2^3}{12} = 300 \cdot 1000 \frac{19^3}{12} = 1,715 \times 10^8 \text{ Nmm}^2$$

$$E_3 b \frac{h_3^3}{12} = 11000 \cdot 1000 \frac{34^3}{12} = 3,603 \times 10^{10} \text{ Nmm}^2$$

$$E_4 b \frac{h_4^3}{12} = 300 \cdot 1000 \frac{19^3}{12} = 1,715 \times 10^8 \text{ Nmm}^2$$

$$E_5 b \frac{h_5^3}{12} = 11000 \cdot 1000 \frac{34^3}{12} = 3,603 \times 10^{10} \text{ Nmm}^2$$

$$(EI)_A = 1,084 \times 10^{11} \text{ Nmm}^2$$

Proračun krutosti virtualne grede B

Stiffness calculation for the virtual beam B

$$(EI)_B = \sum_{i=1}^n E_i \cdot A_i \cdot Z_i^2$$

$$E_1 \cdot A_1 \cdot Z_1^2 = 11000 \cdot 1000 \cdot 34 \cdot 53^2 = 1,051 \times 10^{12} \text{ Nmm}^2$$

$$E_2 \cdot A_2 \cdot Z_2^2 = 300 \cdot 1000 \cdot 19 \cdot 26,5^2 = 4,003 \times 10^9 \text{ Nmm}^2$$

$$E_3 \cdot A_3 \cdot Z_3^2 = 11000 \cdot 1000 \cdot 34 \cdot 0 = 0 \text{ Nmm}^2$$

$$E_4 \cdot A_4 \cdot Z_4^2 = 300 \cdot 1000 \cdot 19 \cdot (-26,5)^2 = 4,003 \times 10^9 \text{ Nmm}^2$$

$$E_5 \cdot A_5 \cdot Z_5^2 = 11000 \cdot 1000 \cdot 34 \cdot (-53)^2 = 1,051 \times 10^{12} \text{ Nmm}^2$$

$$(EI)_B = 2,110 \times 10^{12} \text{ Nmm}^2$$

Efektivna krutost je

Effective stiffness is:

$$(EI)_{ef} = (EI)_A + (EI)_B = 1,084 \times 10^{11} + 2,110 \times 10^{12} = 2218 \times 10^9 \text{ Nmm}^2$$

6 ZAKLJUČAK

Primenom CLT u konstrukcijama postiže se zdrav i prirodan ambijent. CLT konstrukcije su čvršće i imaju bolje statičke osobine od monolitnog drveta, nemaju sklonost ka uvijanju, a pojava napuklina svedena je na minimum. Karakteriše ih velika požarna otpornost, kao i visoka otpornost na potres. Izgradnja CLT konstrukcije brža je oko 30% nego kada se koristi odgovarajuća betonska konstrukcija, jer se drveni elementi isporučuju kao prefabrikovani, koji se zatim brzo uklapaju na gradilištu. Za CLT panele koristi se mekano drvo koje raste brzo i kog ima u izobilju, pa je i cena CLT konstrukcija niža od 5 do 10% od odgovarajućih betonskih ili čeličnih. Drvo je i mnogo bolji izolator - pet puta bolji od betona i čak 350 puta bolji od čelika.

U radu su prikazane analitičke metode proračuna koje se najčešće koriste prilikom dimenzionisanja CLT konstrukcija. Gamma metod daje jednostavan postupak proračuna, ali vrednost efektivne krutosti panela u prikazanom primeru manja je za oko 6% u poređenju s druge dve metode. Efektivne krutosti panela sračunate K-metodom i Kreuzinger-ovom analogijom imaju istu vrednost, ali je postupak proračuna K-metodom znatno kraći i jednostavniji.

Usvajanjem predloženog međunarodnog standarda EN 16351 Timber structures - Cross laminated timber - Requirements u svim državama Evrope postigao bi se jedinstveni analitički pristup prilikom dimenzionisanja. U

6 CONCLUSION

Use of CLT creates healthy and natural ambiance. Compared against traditional wood, CLT construction are stronger, have better mechanical properties, no bending tendency, and minimal fractures appearance. CLT constructions are characterized by high fire resistance, and resilience to earthquakes. Since the elements are delivered prefabricated and can be assembled quickly on the construction site, CLT constructions can be completed roughly 30% faster than comparable concrete projects. Fast growing easily accessible softwood keeps the price of CLT 5 to 10% lower than the competing concrete or steel construction. Timber is 5 times better insulator than concrete and up to 350 times better than steel.

This work presents the most frequently used analytical design methods. Even though Gamma method is a simple design procedure for CLT constructions, result in the shown example for effective stiffness of the panel is about 6% lower compared to other two methods. When calculated using both K-method, and Kreuzinger analogy, panels' effective stiffness values yield same results; however, K-method design procedure is considerably shorter and simpler.

By adopting the international standard EN 16351 Timber Structures – Cross laminated timber – Requirements across all European countries the unified design approach could be achieved. In Serbia the

Srbiji, prevod ovog standarda obuhvaćen je planom rada Instituta za standardizaciju Srbije, a njegovo prihvatanje očekuje se krajem 2015. godine.

7 LITERATURA REFERENCES

- [1] Sylvain Gagnon, M. Mohammad: *Structural Performance and Design of CLT Building*, CLT Symposium and Workshop, Moncton, NB, October 12, 2011.
- [2] Ian Smith, Andrea Frangi: *Use of Timber in Tall Multi-Storey Buildings*, International Association for Bridge and Structural Engineering (IABSE), Zurich, Switzerland, 2014.
- [3] *Handbook cross-laminated timber*, FPInnovations and Binational Softwood Lumber Council, 2011.
- [4] Gerhard Shickhofer: *CLT - European Experience*, Presentation in the frame of the CLT Forum 2013 in Tokyo.
- [5] European technical approval ETA-06/0138 Validity from 01.07.2011 to 30.06.2016, extends ETA-06/0138 with validity from 27.07.2006 to 26.07.2011.
- [6] Ben Toosi: *Cross Laminated Timber, The Market Opportunities in North America*, FPInnovations, Canada, May 12th 2011.

REZIME

UNAKRSNO LAMELIRANI DRVENI ELEMENTI U SAVREMENIM DRVENIM KONSTRUKCIJAMA ZGRADA - primena i proračun

Ljiljana KOZARIĆ
Aleksandar PROKIĆ
Miroslav BEŠEVIĆ

U radu se analizira unakrsno lamelirano drvo (CLT), moderan građevinski materijal koji se proizvodi od osušenih drvenih elemenata - lamela. Lamele u CLT panelima su podjednake širine i postavljene su tako da vlakna drveta u lamelama po slojevima budu međusobno pod pravim uglom.

Prikazane su osnovne fizičko-mehaničke karakteristike CLT panela, kao i analitički modeli koji se najčešće koriste prilikom projektovanja CLT podnih i zidnih elemenata u konstrukcijama. Navedene su prednosti i nedostaci ovog novog konstruktivnog sistema, u skladu sa savremenim svetskim zahtevima pri projektovanju modernih, ekološki prihvatljivih konstrukcija.

Cljučne reči: unakrsno lamelirano drvo, savremene drvene konstrukcije

proposal of the standard has been made the part of the agenda of the Institute for Standardization and its adoption could be finalized by the end of 2015.

- [7] <http://www.drvotehnika.info/clanci/drvo-kao-gradjevinski-materijal-zgrada-od-drveta>, 15.03.2015
- [8] <http://www.woodsolutions.com.au/Inspiration-Case-Study/forte-living>, 17.03.2015.
- [9] <http://www.drvotehnika.info/clanci/drvo-kao-gradjevinski-materijal-zgrada-od-drveta>, 15.03.2015.
- [10] Sylvain Gagnon: *Structural Design of CLT in Canada*, Québec City, May, 2010.
- [11] Evrokod 5 - Proračun drvenih konstrukcija - Deo 1-1: Opšta pravila i pravila za zgrade, EN 1995-1-1:2004, Beograd, 2009.
- [12] Hans Joachim Blass, Peter Fellmoser: *Design of solid wood panels with cross layers*, Proceedings, 8. World Conference on Timber Engineering, Lahti, Finland, 2004.

SUMMARY

CROSS LAMINATED TIMBER ELEMENTS IN CONTEMPORARY TIMBER STRUCTURES OF BUILDINGS - application and design

Ljiljana KOZARIĆ
Aleksandar PROKIĆ
Miroslav BEŠEVIĆ

This work analyses cross laminated timber (CLT), contemporary building material produced of dried wooden elements - laminates. Laminates in CLT panels are equally wide and timber fibers are rectangularly plated within layers.

Paper shows basic physical - mechanical characteristics of CLT panels and analytic models that are most commonly used in designing of CLT floor and wall construction elements. Advantages and disadvantages of this new construction system are stated according to contemporary requirements in designing environmentally and ecologically acceptable constructions.

Key words: cross laminated timber, contemporary timber structures