

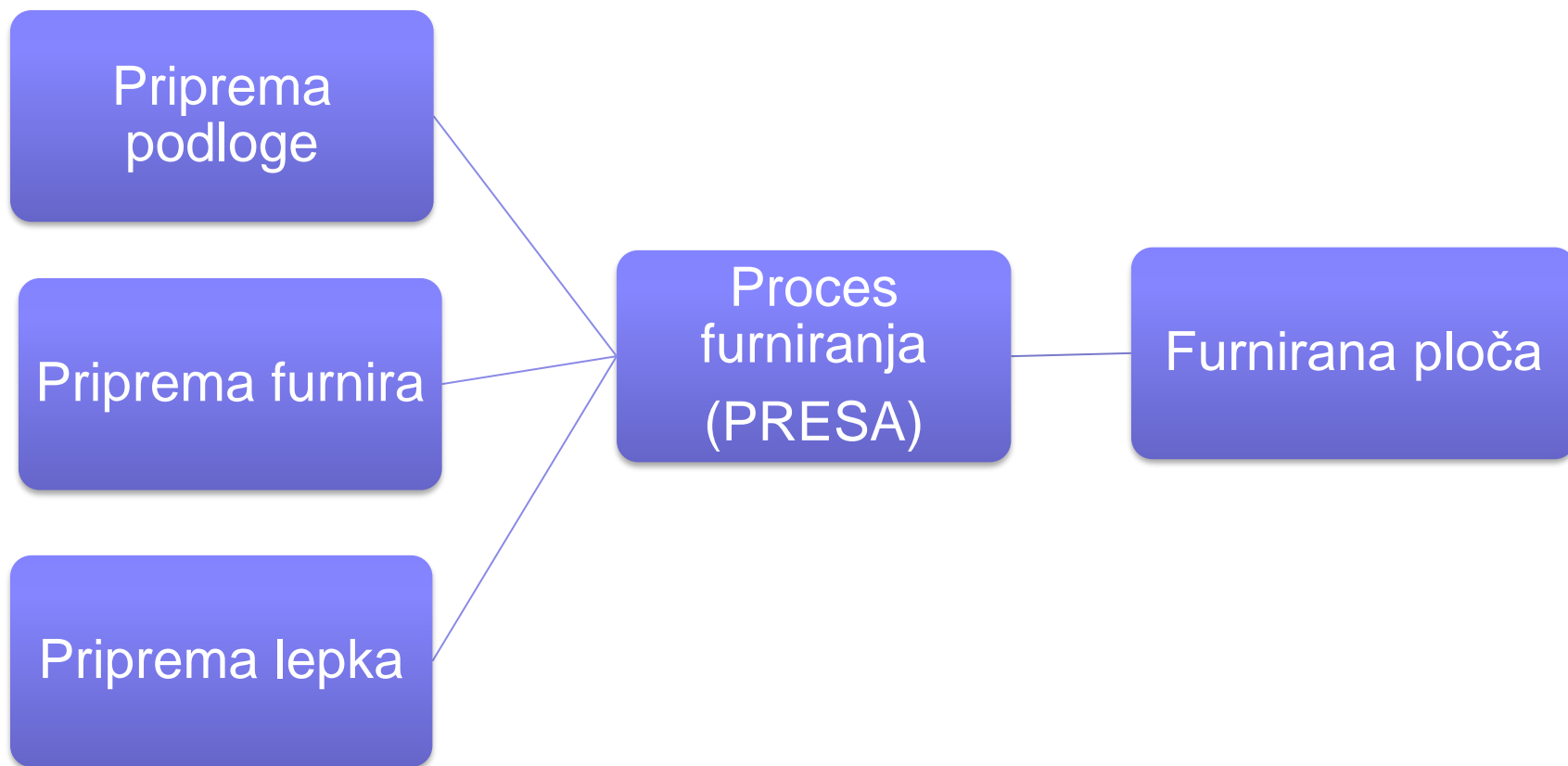

Krojenje (priprema) furnira

Furniranje širih strana ploča furnirom



Piprema furnira obuhvata:

- Odabir i obeležavanje furnira
- Izravnavanje paketa
- Obeležavanje paketa
- Krojenje paketa
- Spajanje listova u plašt
- Kontrola i dorada plašta

Odabir furnira:

- Po kvalitetu
- Po boji
- Po teksturi
- Po dimenzijama

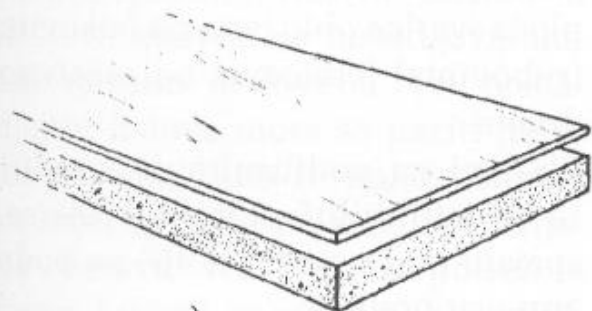

a)

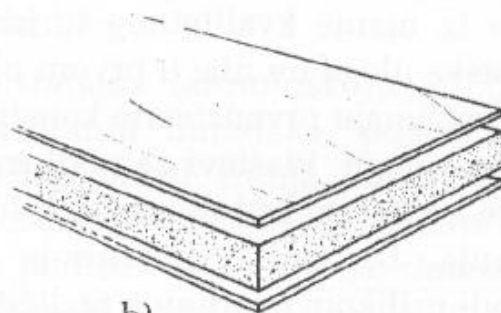

b)

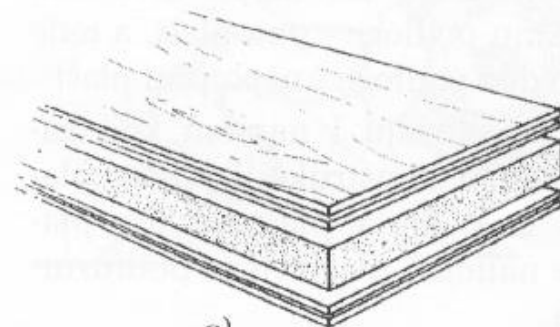

c)

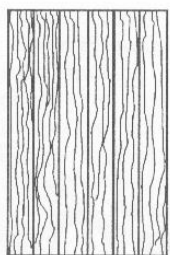

a)

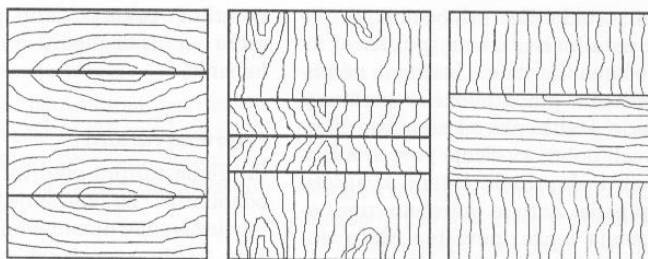

b)

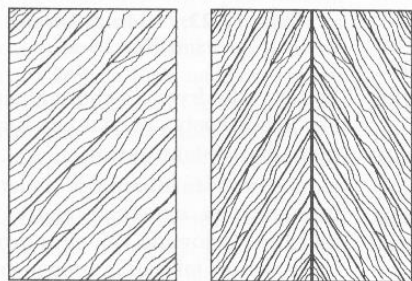

c)

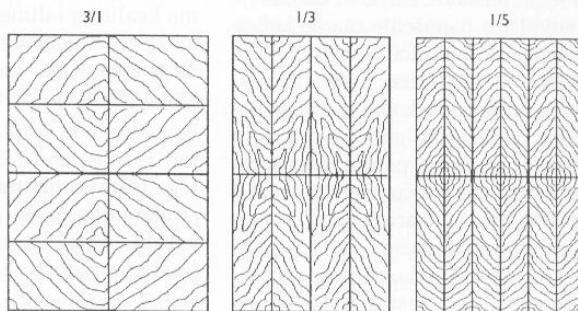

d)

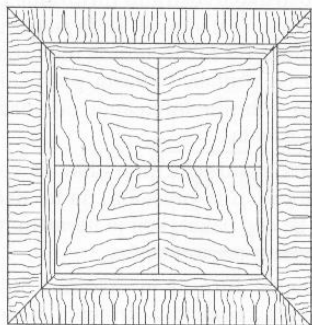

e)

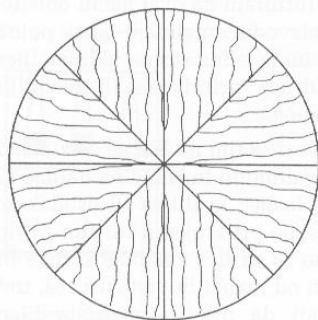

f)

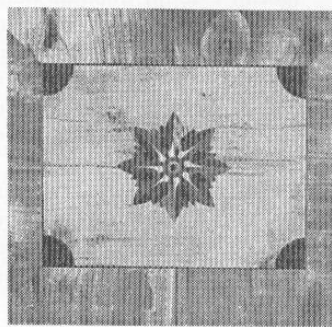

g)

Načini formiranja plaševa

- a) Podužno
- b) Poprečno
- c) Koso
- d) Krstasto
- e) Kombinovano
- f) Kružno
- g) Intarzijsko

Obeležavanje paketa

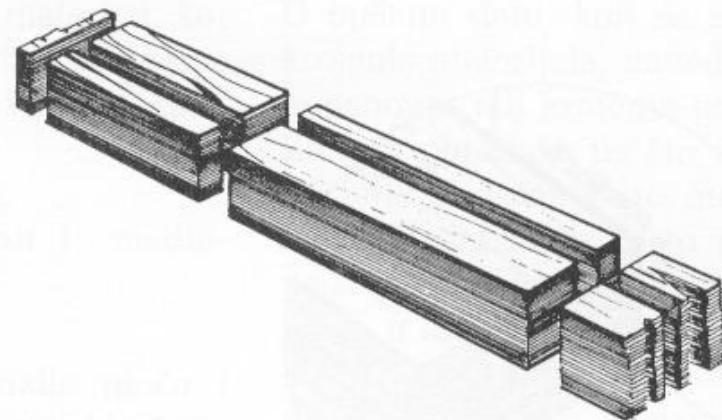
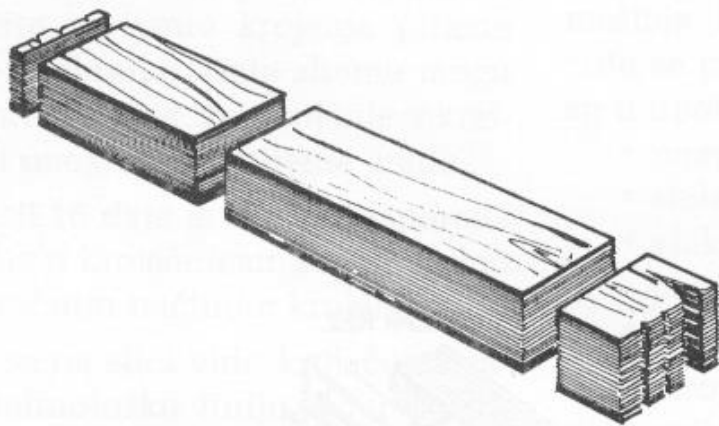

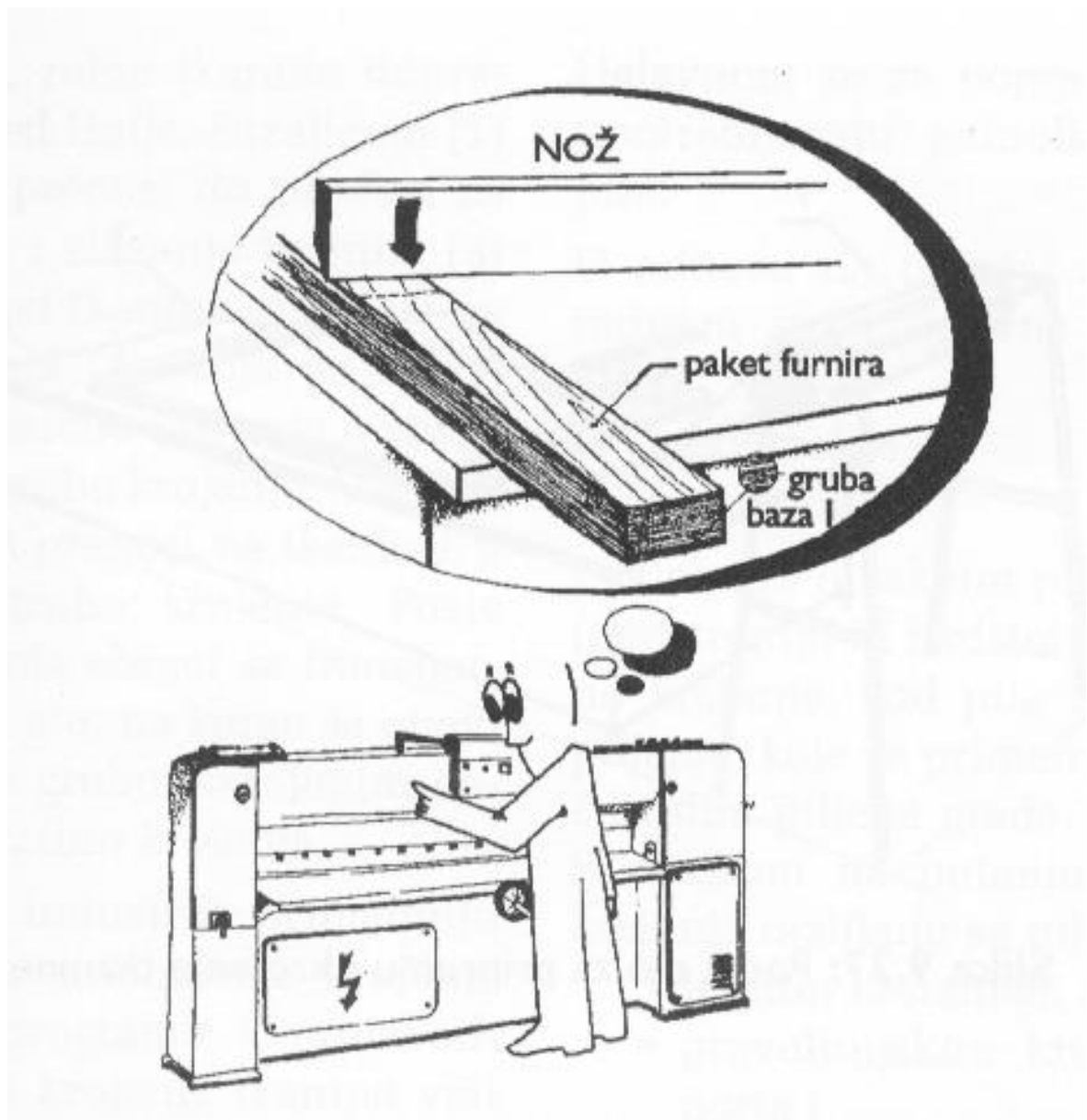

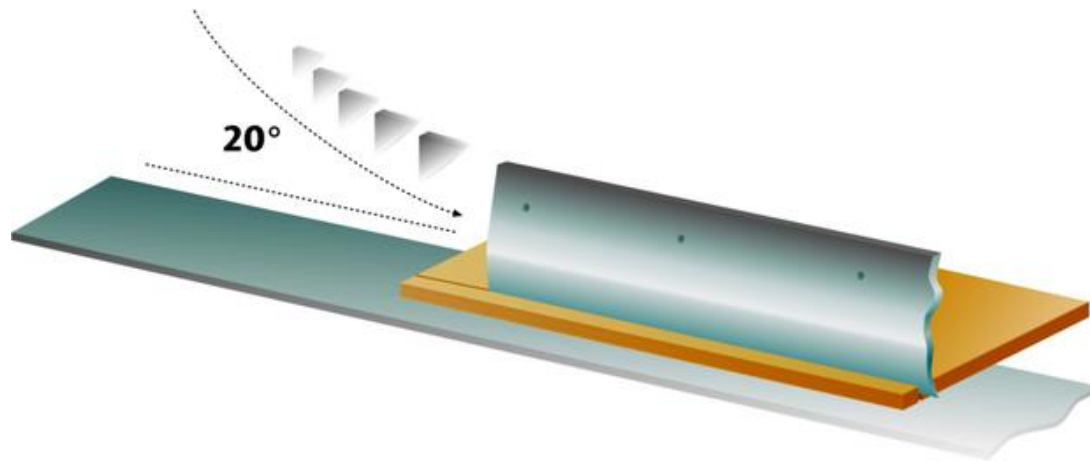



L noža = 800mm

H obrade = 80mm

P = 3 KW

Dimenzije mašine L x B = 1,5 x 0,6m



CASATI

POZICIJA 2

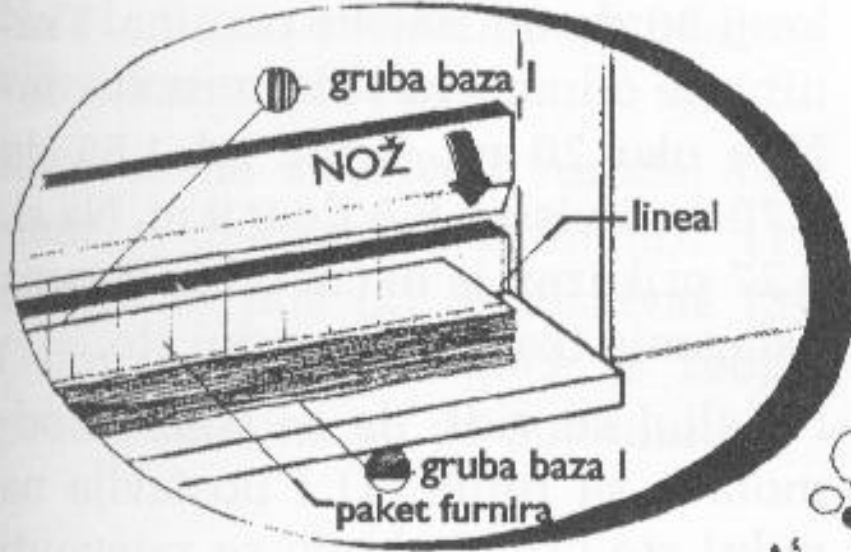

POZICIJA I

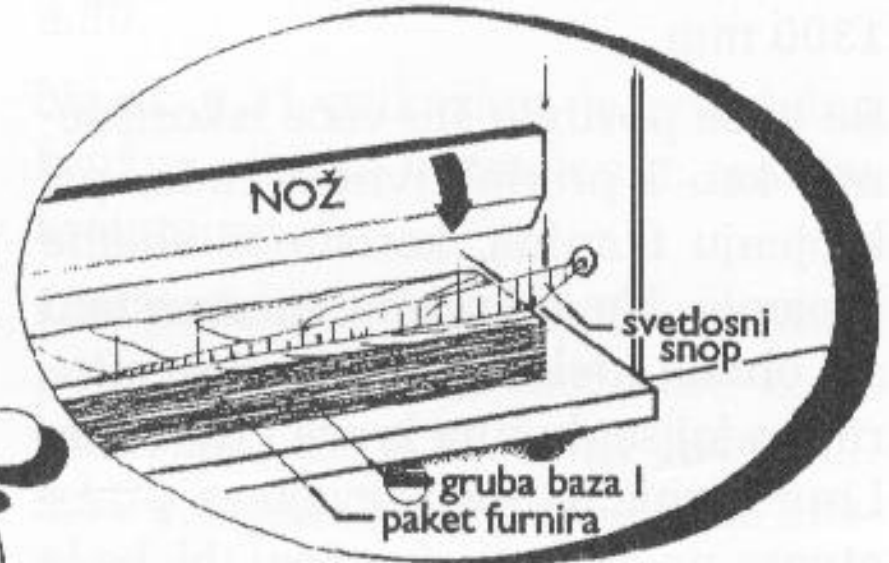

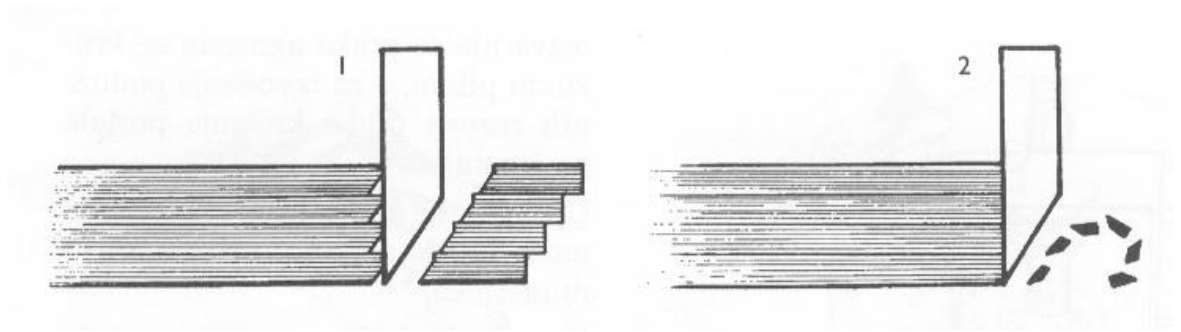



L noža = 3500mm

H obrade = 80mm

P = 7,5 KW

Dimenzije mašine L x B = 4,5 x 1,7m

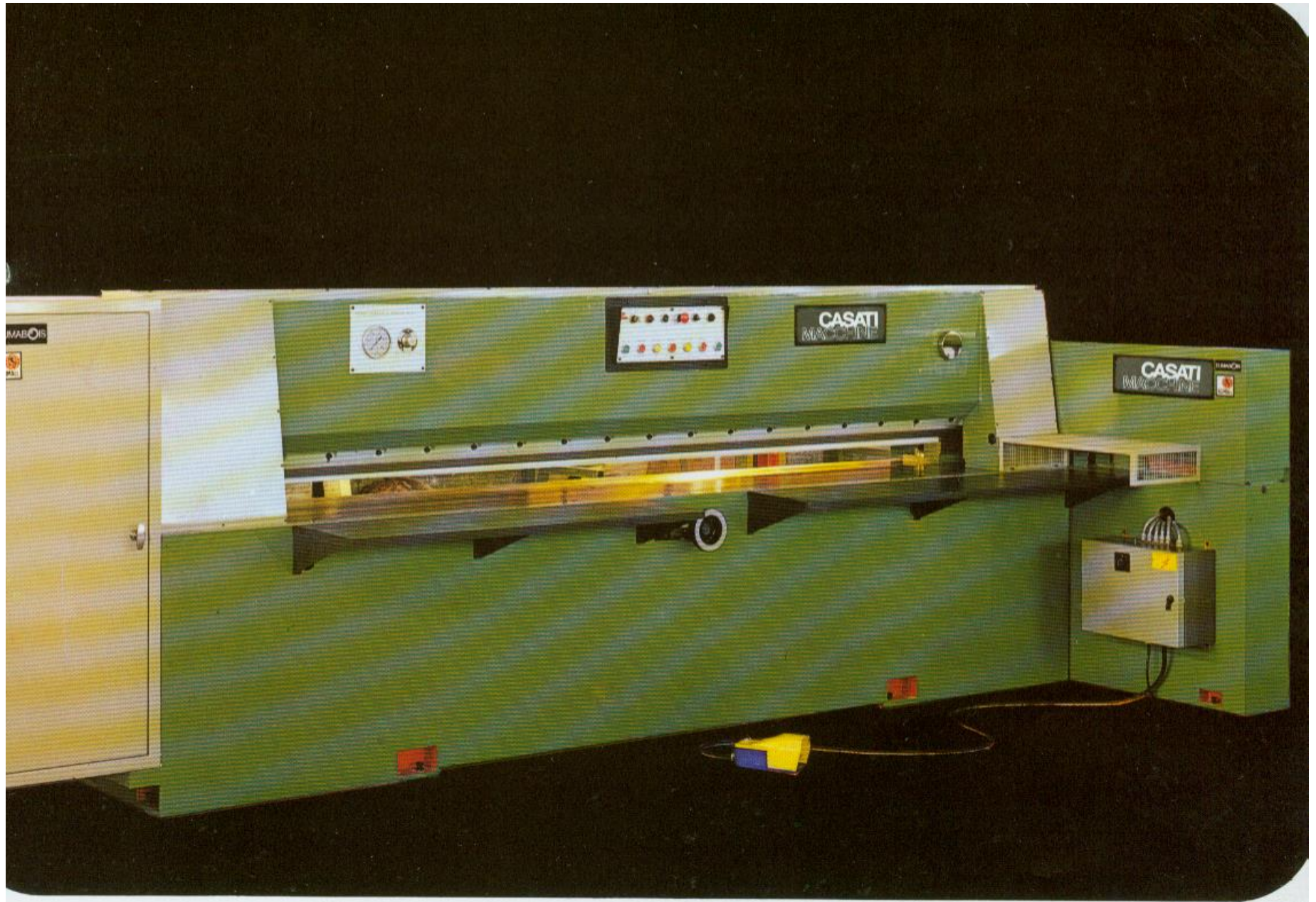

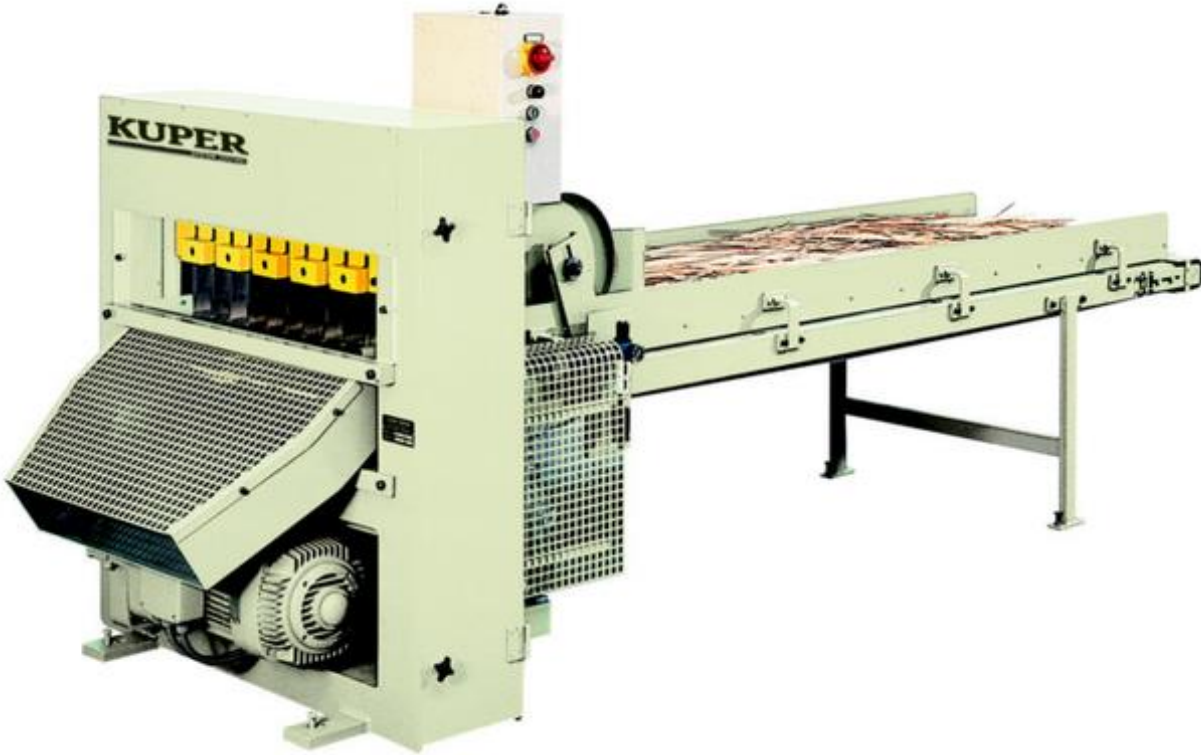









Dubina obrade = 1200mm

$U = 20 \div 60 \text{ m/min}$

$D = 0,4 \div 3\text{mm}$

$L \times B = 2,2 \times 0,7 \text{ m}$

